

TYPICAL ROOF BRACKET CONNECTION  
(N 3.1 BRACKET SHOWN)

1  
—

NTS

NOTES:

- HOLES CAST IN BRACKET ARE A VERTICAL SHORT-SLOT, HOLES IN COLUMN ARE OVERSIZE PER AISC SPECIFICATION TABLE J3.3.
- SHIM GAP WITH FINGER SHIMS PRIOR TO TIGHTENING BOLTS.
- SEE STEEL CAST CONNECTIONS FOR FILLET WELD SIZE, *tw*.
- BOLTED BRACKETS ARE SUPPLIED COMPLETE WITH A490 BOLTS AND WASHERS FROM STEEL CAST CONNECTIONS, LLC, SEATTLE, WA. PHONE: (206) 250-7035.

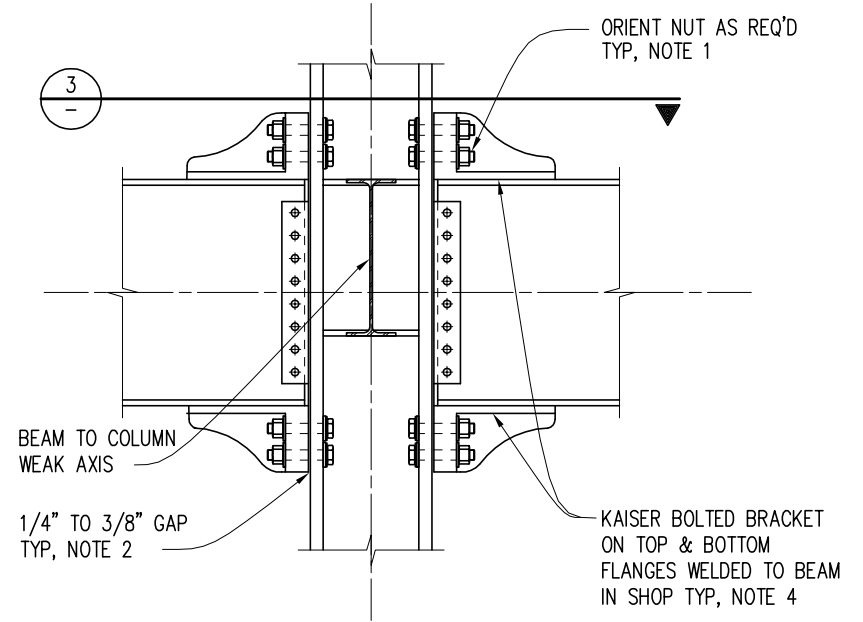

TYPICAL FLOOR BRACKET CONNECTION  
(N 2.1 BRACKET SHOWN)

2  
—

NTS

SHOP WELD BRACKETS TO BEAM BOTH SIDES, TYP, NOTE 3

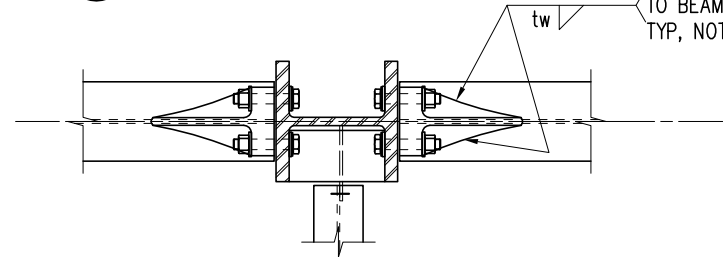

3  
—

BRACKET CONNECTION PLAN

NTS



BOLTED BRACKET

DETAILS

PROJ NO:  
105537  
DATE:  
2/6/06  
DRAWN BY:  
J. PENNELL

SK-1